

**Istruzioni di montaggio**  
**Assembling instructions**  
**Notice de montage**  
**Montageanleitung**  
**Manual de montaje**

Portata massima:  
 Maximum load:  
 Charge maxi:  
 Maximale belastbarkeit:  
 Carga maxima:

**25 Kg**

**Reversibile - Reversible**  
**Rèversible - Reversibel - Reversible**  
**EUK45PAT...**

**Dx**

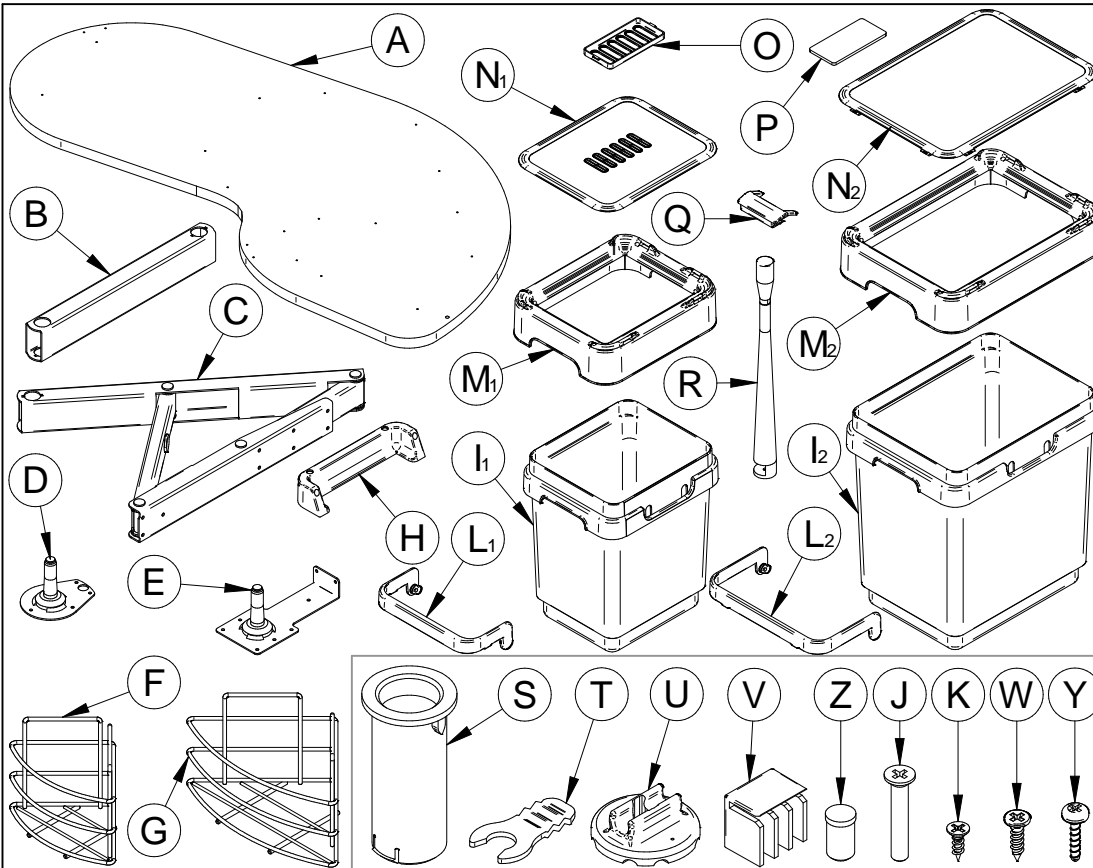
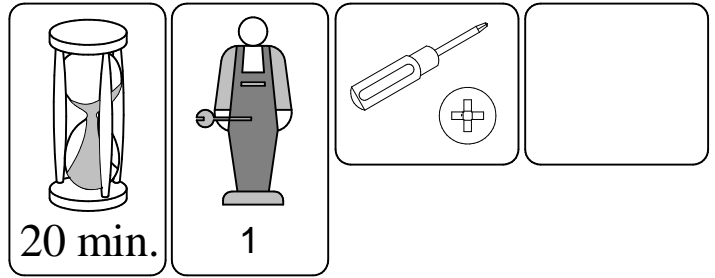
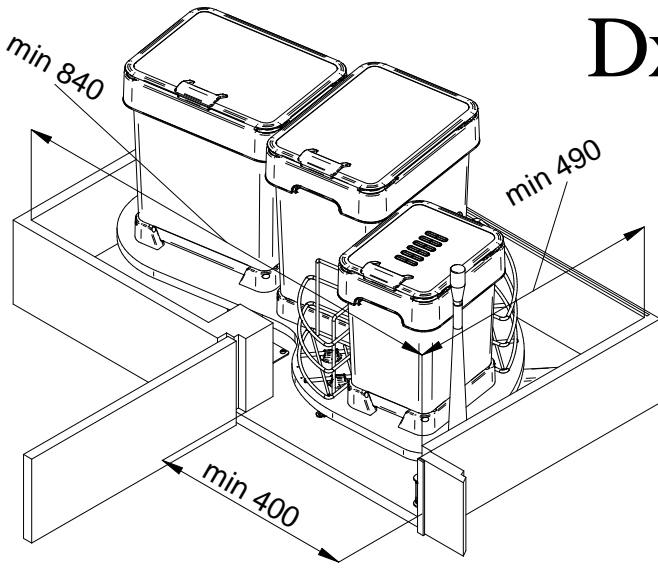

**PRIMA DI COMINCIARE,  
 VEDERE I CONSIGLI DI  
 MONTAGGIO**

BEFORE STARTING, REFER  
 TO THE ASSEMBLING  
 ADVICE IN ANNEX

AVANT DE COMMENCER, SE  
 REPORTER AUX CONSEILS  
 DE MONTAGE EN ANNEXE

VOR DIE MONTAGE, BITTE  
 BEILIEGENDE  
 ANWEISUNGEN FOLGEN

ANTES DE EMPEZAR  
 CONSULTE LOS CONSEJOS  
 PARA EL MONTAJE

A x 1	B x 1	C x 1	D x 2	E x 1	F x 1	G x 1
H x 6	I1 x 1	I2 x 2	L1 x 2	L2 x 4	M1 x 1	M2 x 2
N1 x 1	N2 x 2	O-P x 1	Q x 3	R x 1	S x 3	T x 3
U x 4	V x 3	Z x 12	J x 1	K x 4	W x 12	Y x 25

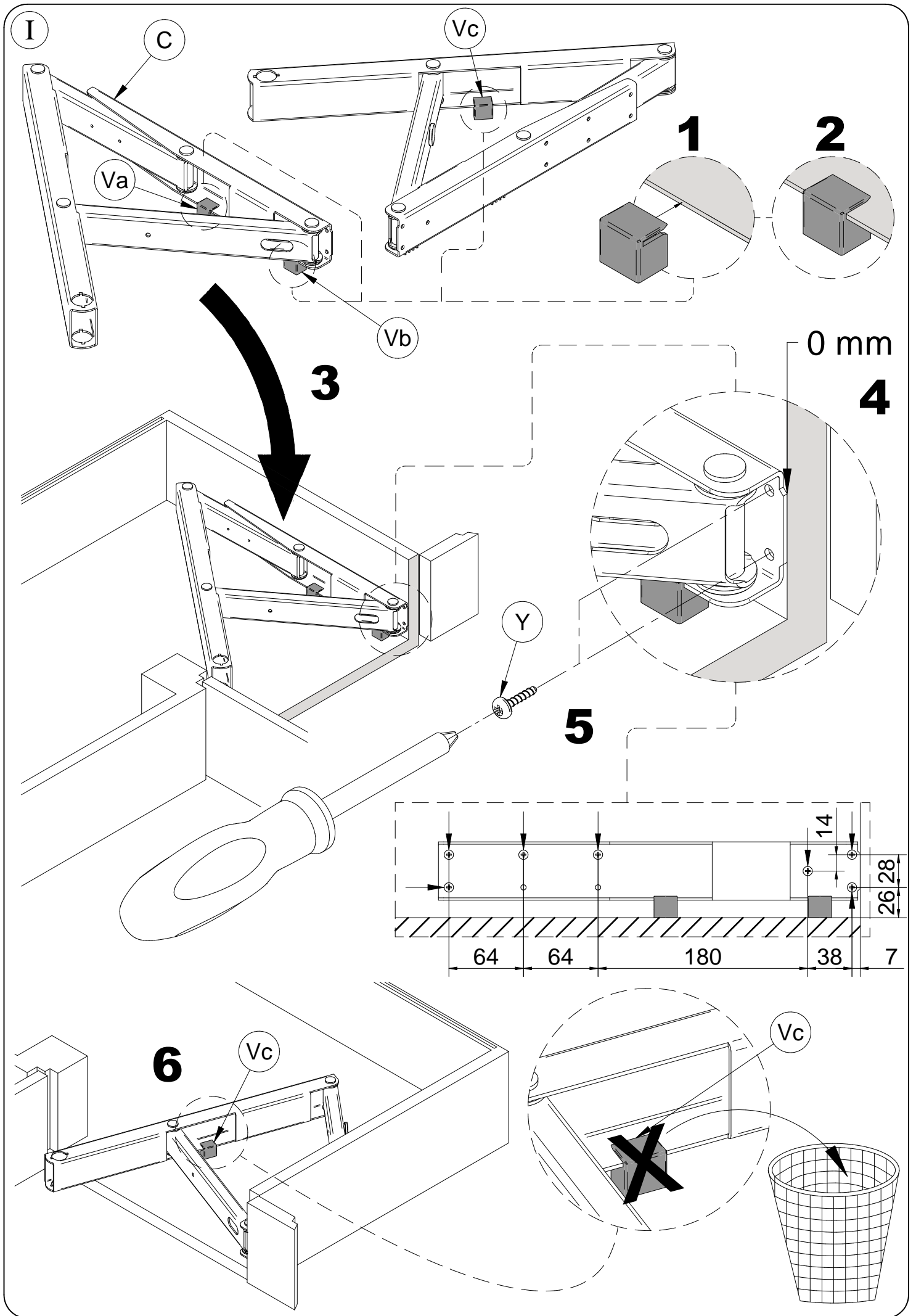

IIa  $X = 98,5\text{mm}$

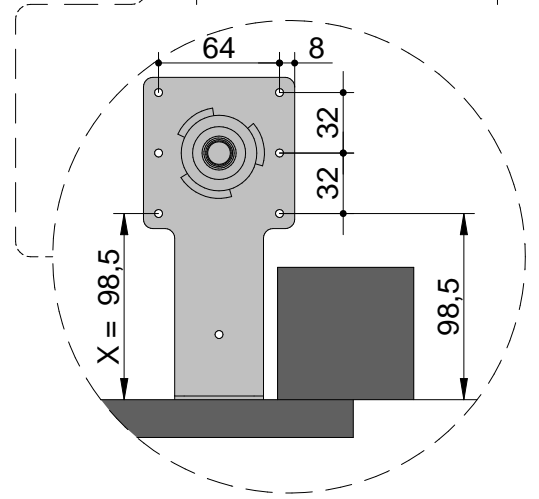
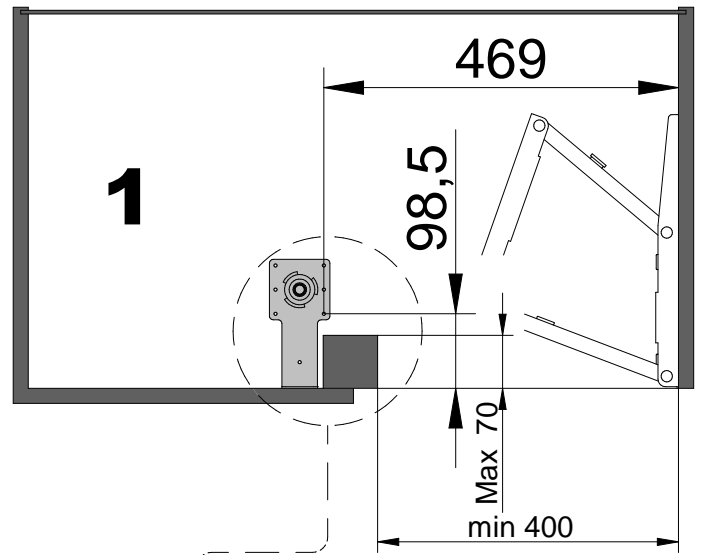
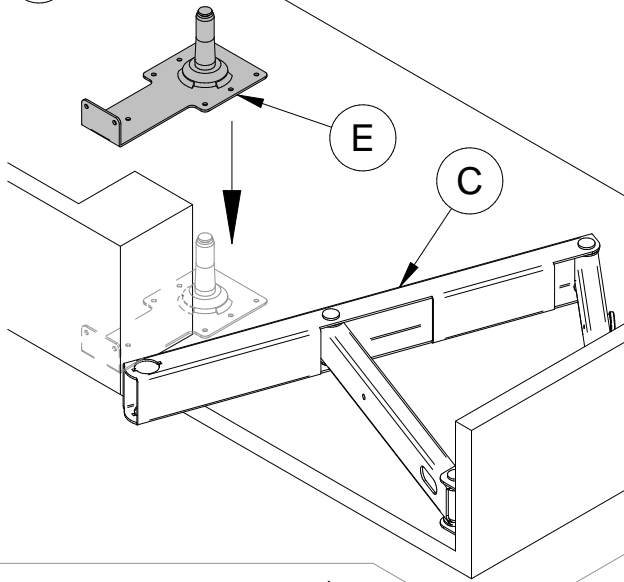

2

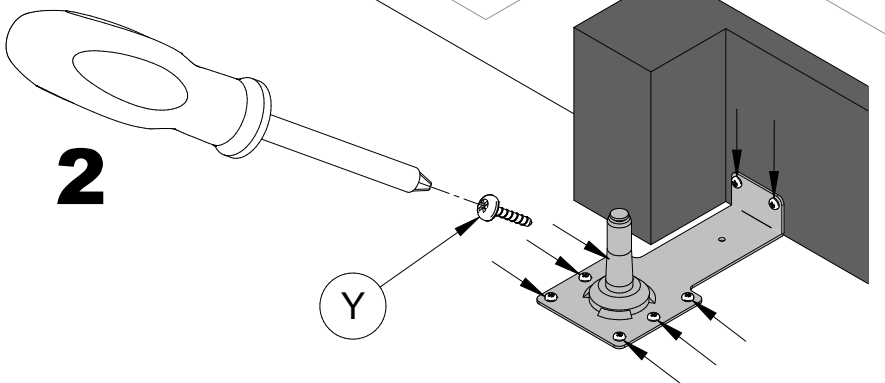

IIb  $X < 98,5\text{mm}$

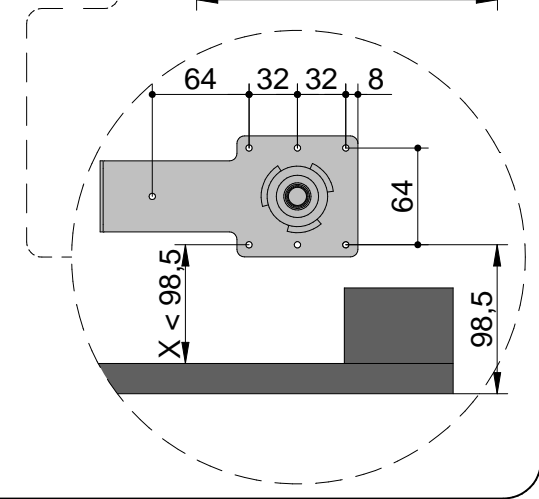
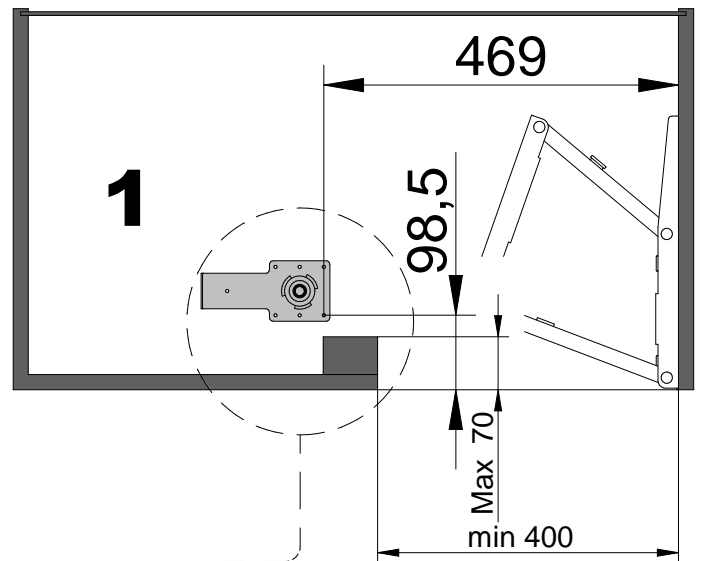
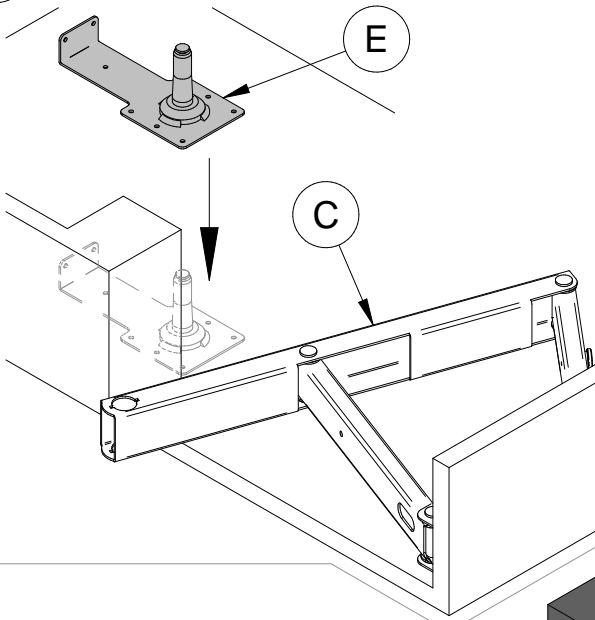

2

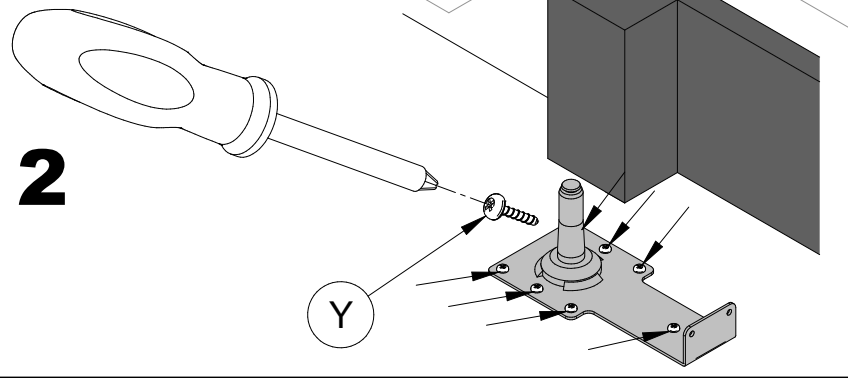

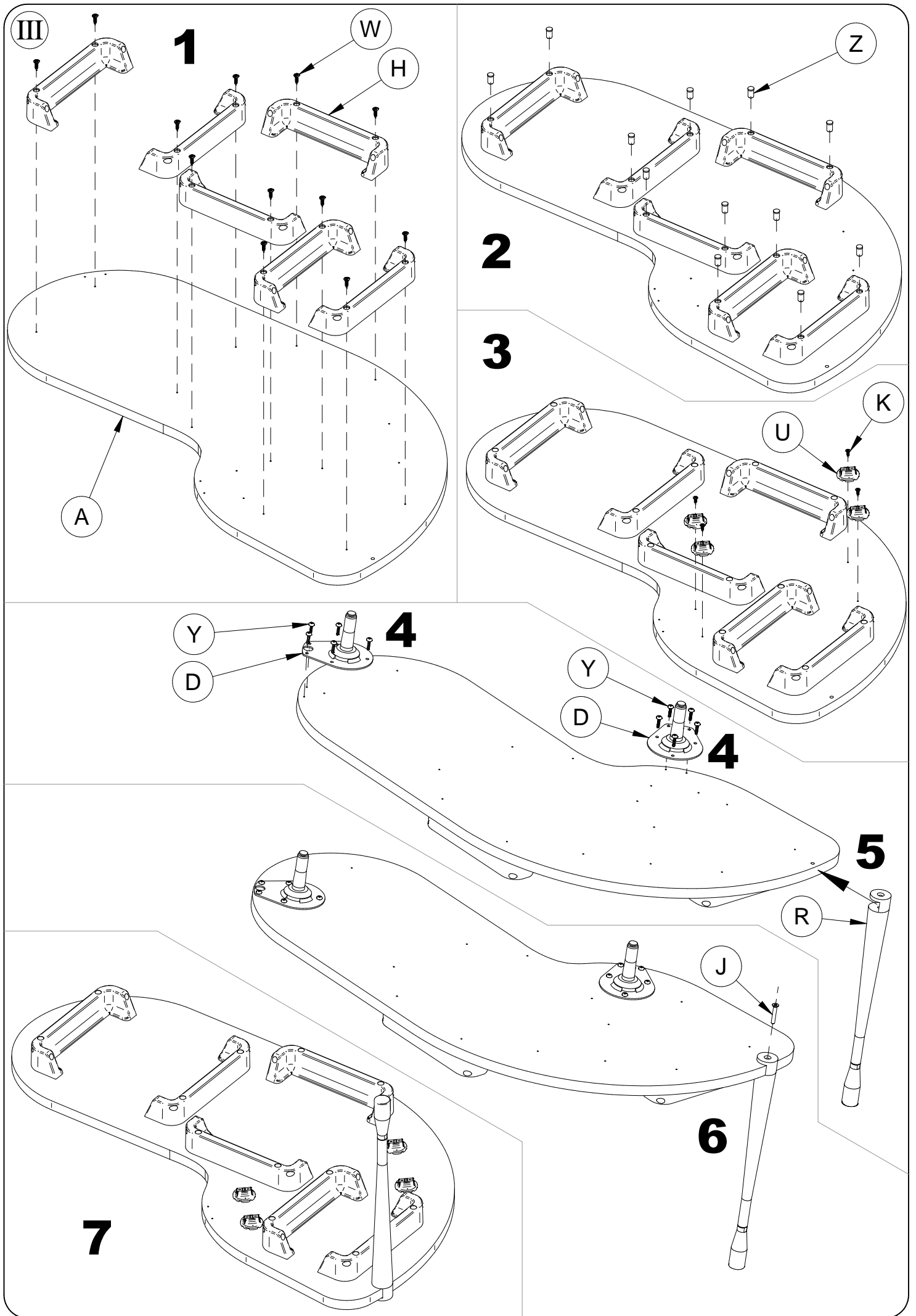

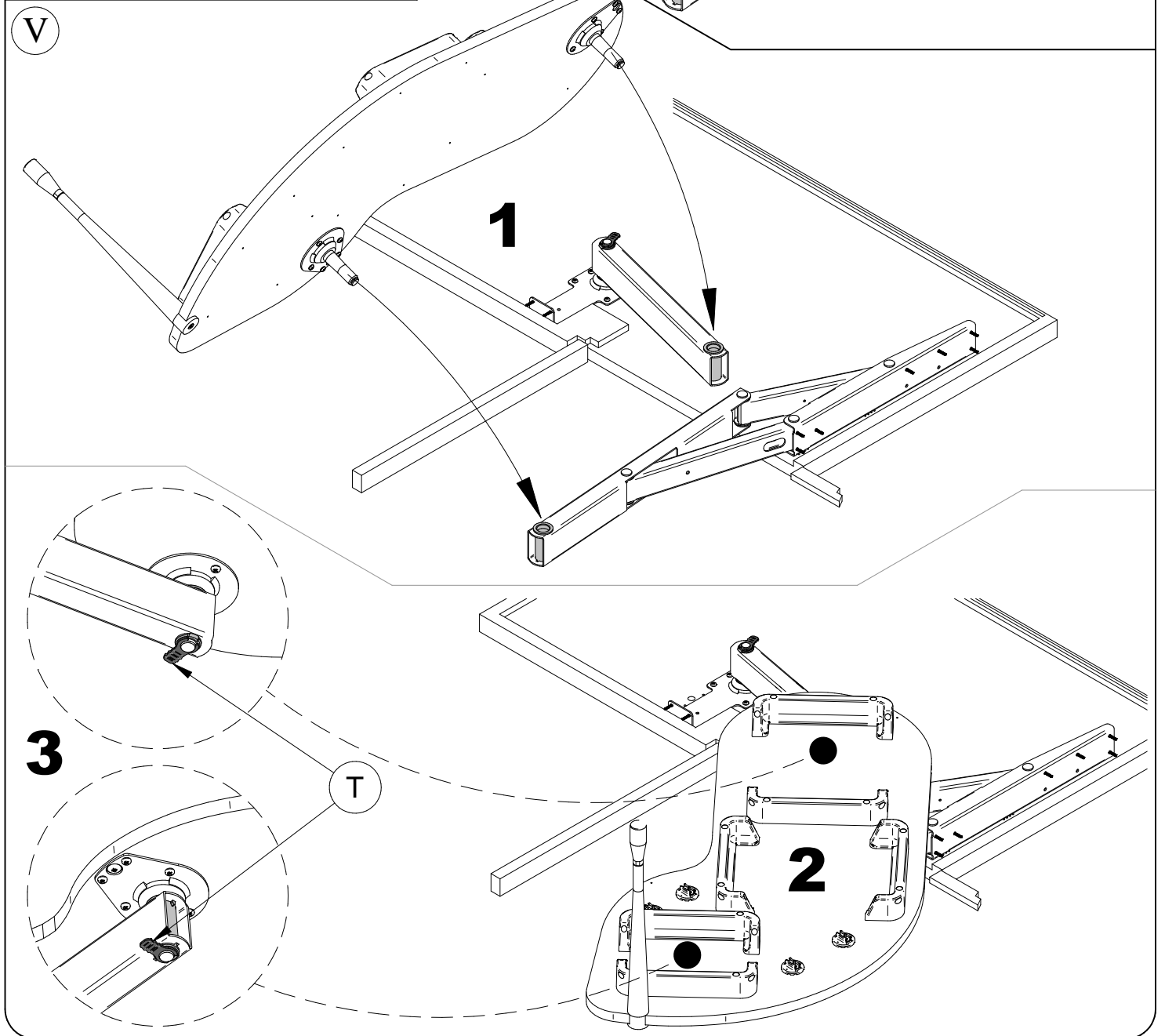
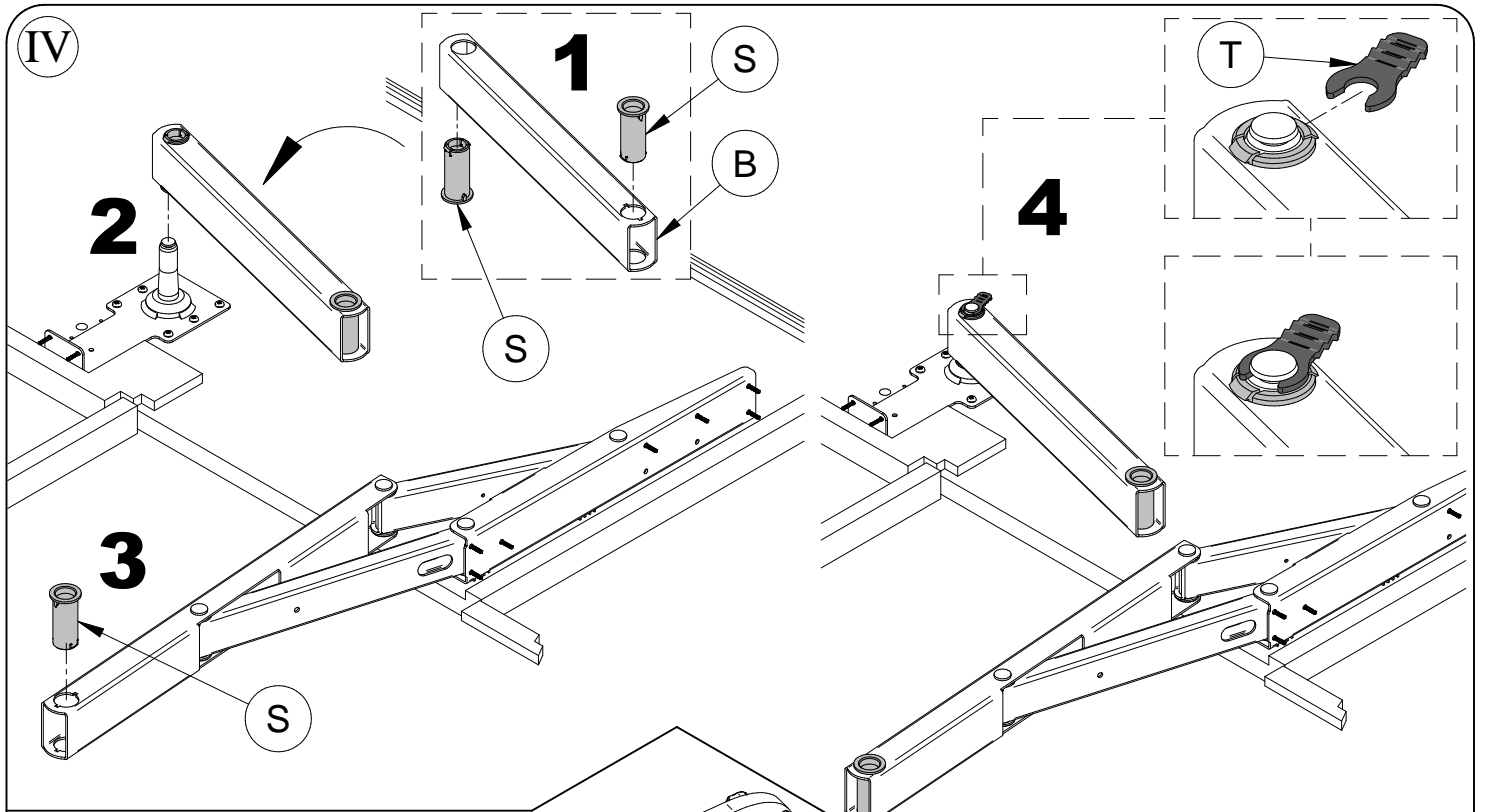

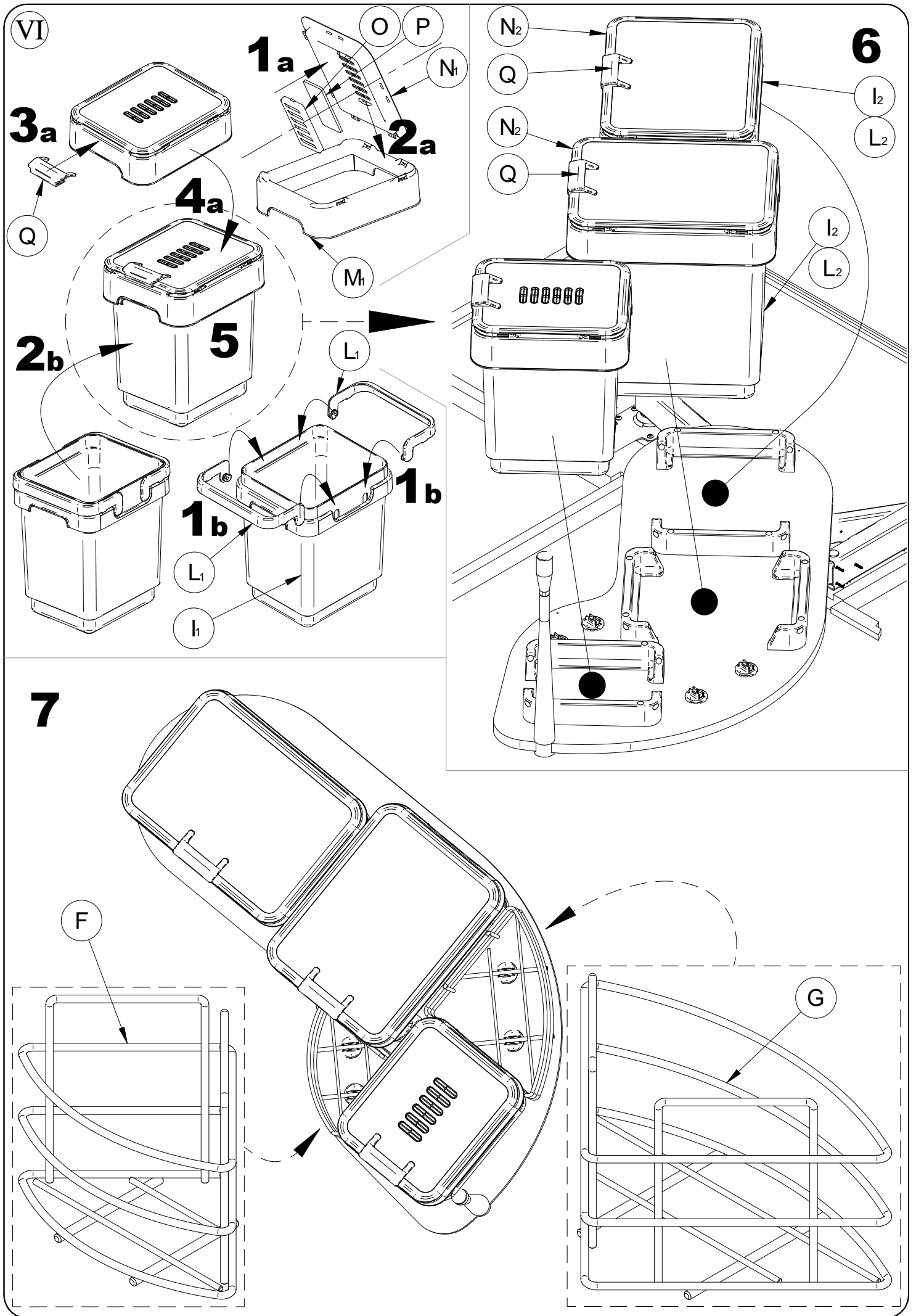

**Istruzioni di montaggio**  
**Assembling instructions**  
**Notice de montage**  
**Montageanleitung**  
**Manual de montaje**

Portata massima:  
 Maximum load:  
 Charge maxi:  
 Maximale belastbarkeit:  
 Carga maxima:

**25 Kg**

**Sx**

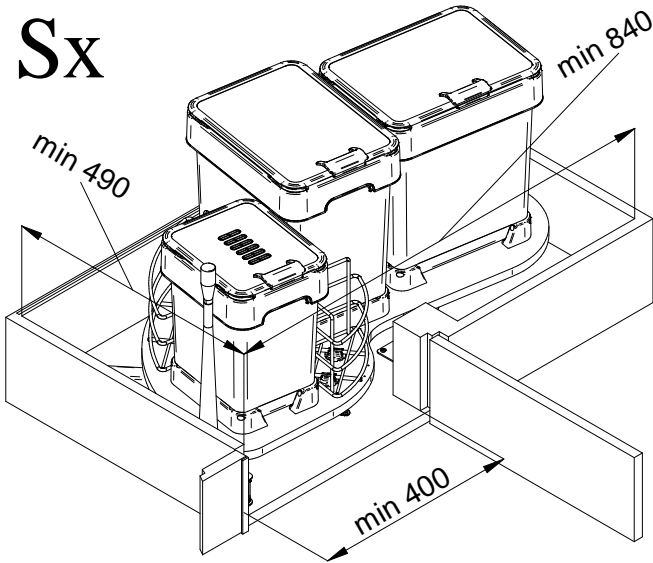

**Reversibile - Reversible**  
**Rèversible - Reversibel - Reversible**  
**EUK45PAT...**

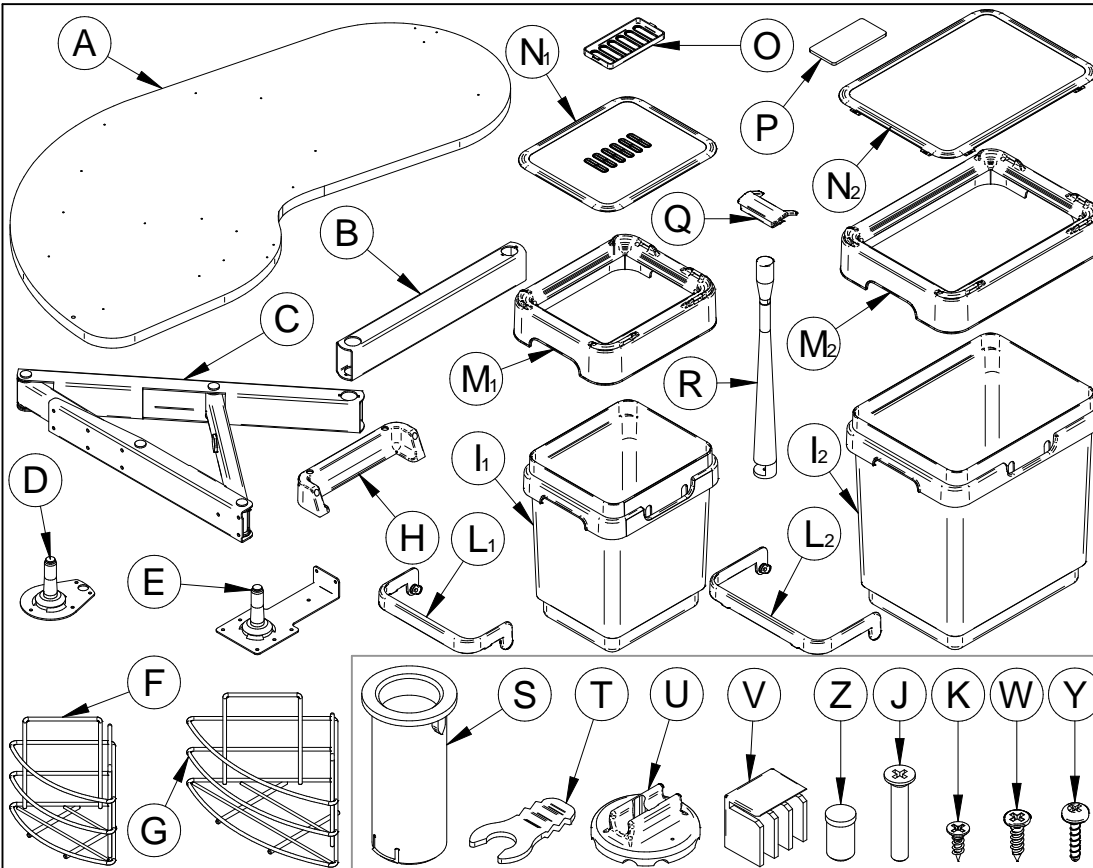
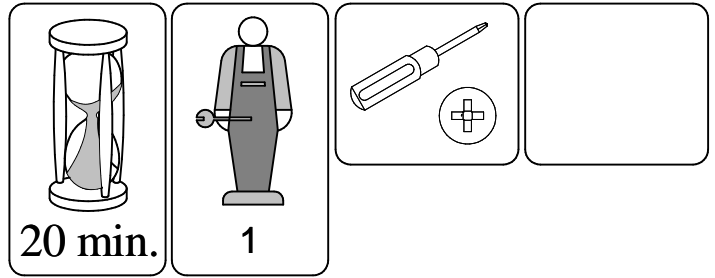

**PRIMA DI COMINCIARE,  
 VEDERE I CONSIGLI DI  
 MONTAGGIO**

**BEFORE STARTING, REFER  
 TO THE ASSEMBLING  
 ADVICE IN ANNEX**

**AVANT DE COMMENCER, SE  
 REPORTER AUX CONSEILS  
 DE MONTAGE EN ANNEXE**

**VOR DIE MONTAGE, BITTE  
 BEILIEGENDE  
 ANWEISUNGEN FOLGEN**

**ANTES DE EMPEZAR  
 CONSULTE LOS CONSEJOS  
 PARA EL MONTAJE**

A x 1	B x 1	C x 1	D x 2	E x 1	F x 1	G x 1
H x 6	I1 x 1	I2 x 2	L1 x 2	L2 x 4	M1 x 1	M2 x 2
N1 x 1	N2 x 2	O-P x 1	Q x 3	R x 1	S x 3	T x 3
U x 4	V x 3	Z x 12	J x 1	K x 4	W x 12	Y x 25

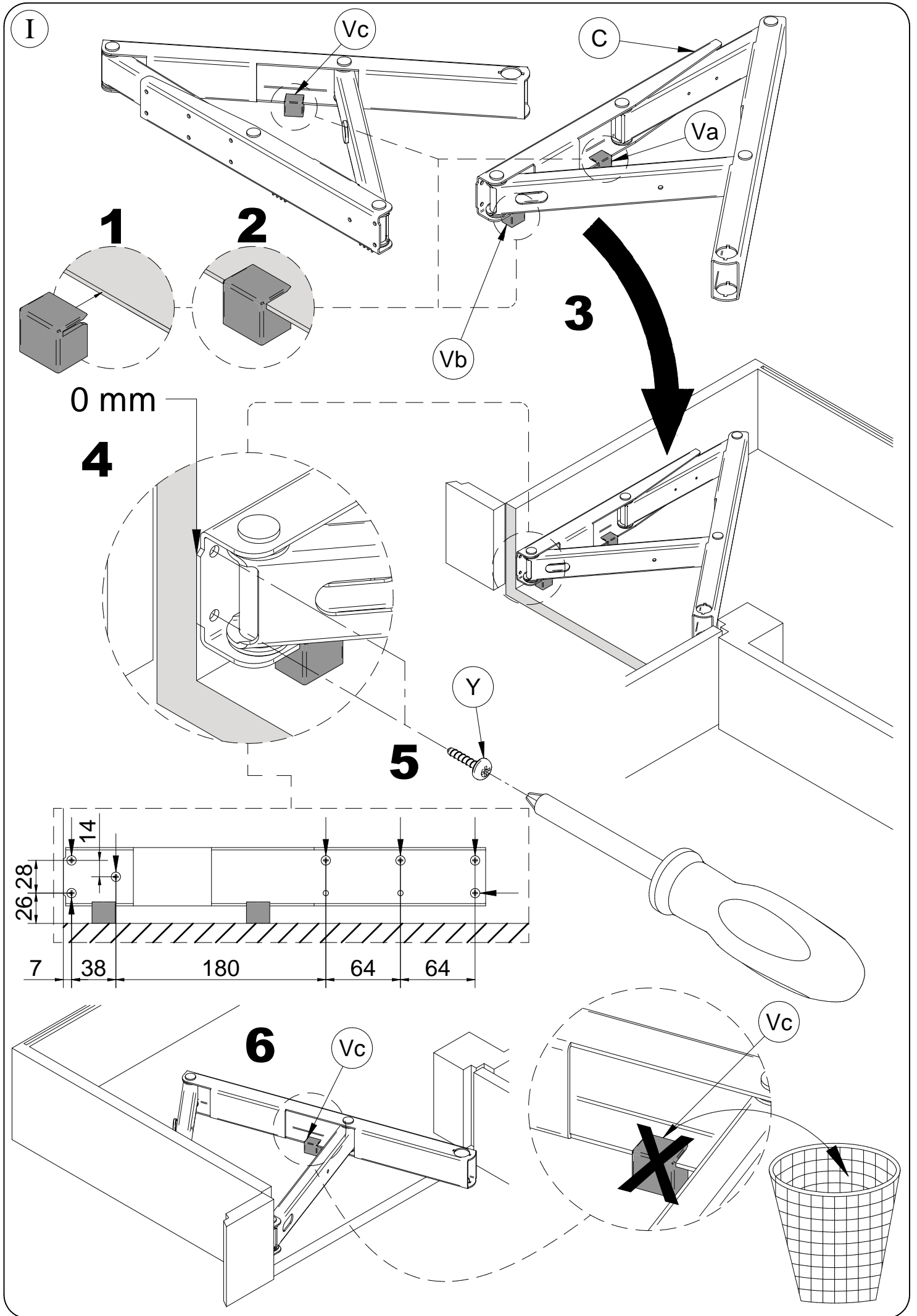



IIa X = 98,5mm

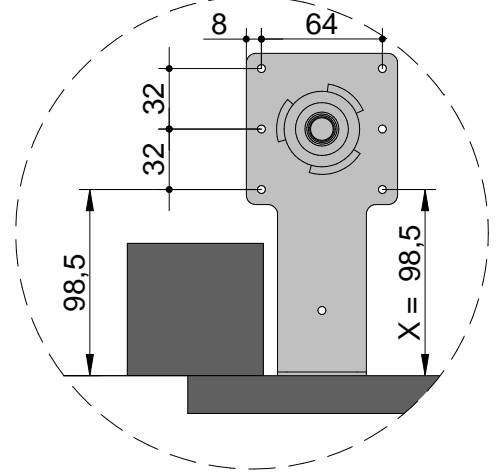
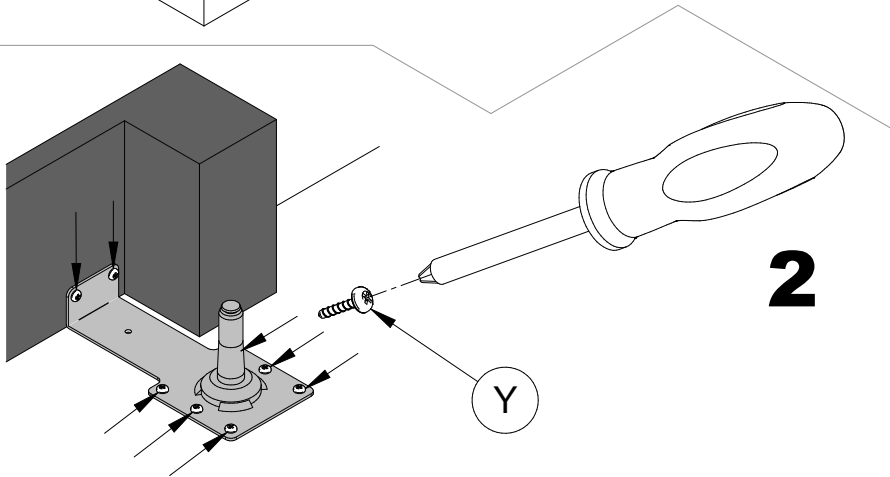
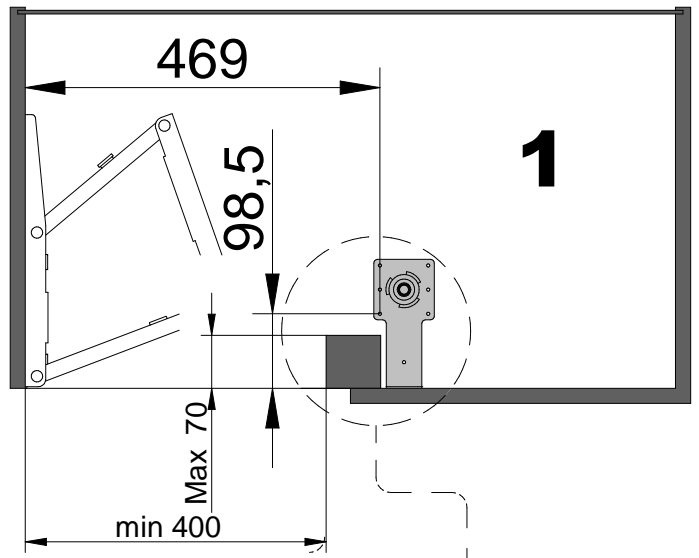
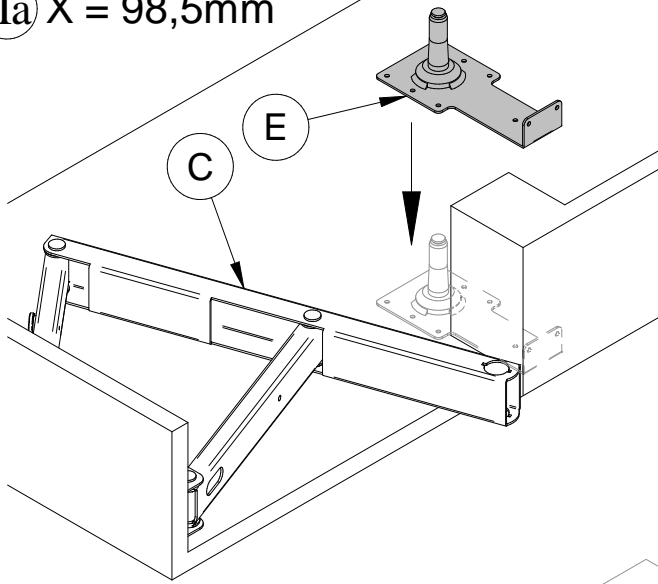

IIb X < 98,5mm

